

TSC 2000



AZIMUT

Industrial Objects Control System

TS 2000

Industrial Objects Control System

Purpose

The industrial objects control system TS 2000 is intended for remote control of industrial objects and monitoring their state. TS 2000 is applied for control power substations of tram and trolleybus networks, distribution and transformer substations of city electric system, street illumination system objects, and equipment of water- and heat-supply systems.



Central Point Module

CP Module

Principle of Operation and Signal Format

The TS 2000 system operates based on the principle of consecutive inquiry of controlled points (CP) with time separations of requests and replay on one and the same carrier frequency. The data exchange between the controller working position (CWP) and the CP is carried out by code words (patterns) via radio channel using phase-manipulated sequences containing data Bits and CRC code. The system provides transmitting telecontrol (TC) commands, telesignalling (TS) and telemeasurements (TM) data requests from the CWP and receiving this data from the CP. The state of all CP included in the system is displayed on the computer monitor. All the changes in the state of CP points and the actions on the CWP are recorded.

Controller working position

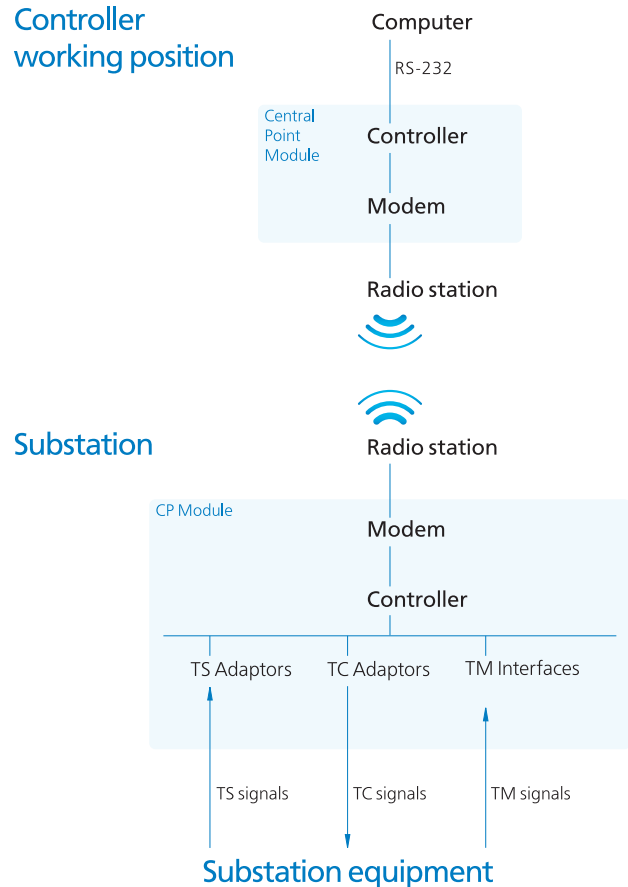

System Composition

The system contains CWP equipment and CP equipment.

The CWP equipment includes:

- central point module;
- radio station;
- computer;
- set of connection cables.

The CP equipment includes:

- CP module;
- radio station;
- set of connection cables.

The system has no fixed configuration and completed from separate parts (central point and CP modules) upon the customer's requirements. The CWP is equipped by a computer with preinstalled software, a radio station and a central point module. The CP modules with radio stations are installed at each controlled point included in the system.

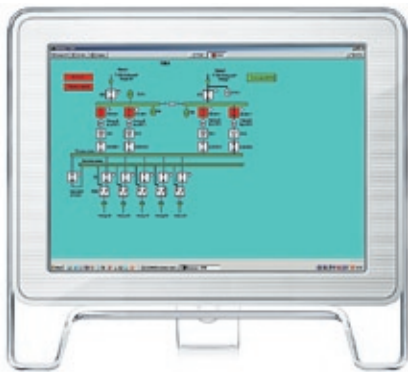

Data Exchange

Telecontrol (TC) commands, state signals (TS) and telemeasuring (TM) results are transmitted through a radio channel to a distance of up to 25 km. "Lyon", "Mayak", "Estakada", "Ecom", "Motorola" and other radio stations are utilized. The information is transmitted on one and the same frequency with temporal separation according to the principle "request from CWP—reply from CP". Any eight controlled points of the system can carry the retransmitter function between the CWP and other CP, which allows to adapt the radio channel structure to the area expansion conditions. The retransmitter mode is also used in order to increase the radio channel range. Reliability of control and state monitoring is achieved due to utilizing software processing methods and interference stability information coding.

Central point module

The central point module as a part of the TS 2000 system provides data exchange between the controlled points and the CWP through a communication line. The module is situated in the CWP and connect to the computer's RS-232 port, to the radio station, and (or) to the wire telephone line. The module is operated under computer control with the installed software of TS-2000 system.

CP Module

The CP module as a part of the TS 2000 system provides collection of equipment state signals (telesignals — TS), measuring sensors (telemearings — TM), and telecontrol command forming (TC). The CP module provides TS and TM data transmission to the CWP upon request of the central point module and executing of the TC commands received from the CWP.

Data Presentation

The system operates under control Windows NT4, Windows 2000, or Windows XP operational systems. The system has a clear and convenient interface. The controlled point equipment configuration is represented in the format of a symbolic circuit which is habitual for the operator. The data representation can be easily configured by means of editing software which provides CP placement configuring, CP symbolic circuits, and operation and control objects. The editing software is included in the software set delivered with the system. All changes and events in the system are recorded and stored in the system during a period set by the system administrator. The archive is arranged as an MS SQL data base. The software includes tools of archive viewing, filtering, and sorting, and review of data base archive in convenient format. The archive data base is open and allows utilizing user's own applications for working with the archive.

Design and Electronic Components

The CP module and CP has been developed on the Comby Card 5000 frame. Interchangeable module devices are unitized. Modern electronic components from a leading world manufacturer is utilized, including programmable microcontroller and modem chips.

Economic efficiency

The experience of TS 2000 implementation for control power substations of tram and trolleybus networks demonstrated that it gets paid for itself within 10–15 months. After the system implementation all the CP are controlled and monitored from CWP. Their staff can be completely discharged (minimum 4 persons at each controlled point) which helps to achieve considerable savings on salary and taxes.

At the same time reliability and efficiency of operation is considerably increased.

Main Technical Specifications of TS 2000

Number of served CPs, up to	127
Informational capacity (number of signals per one CP):	
· telecontrol (TC)	60
· telesignalling (TS)	96
· telemeasurements (TM)	16
State inquiry period of one CP, at most:	
· without retransmission	1.0 s
· with retransmission	1.5 s
TC signal duration at the CP equipment output	0.5 s to 2.0 s
Additional telemeasuring inaccuracy, at most	0.5 %
Probability of wrong reception, not worse than:	
· TS, TV	10^{-6}
· TC	10^{-8}
System response time, at most	3 s
Power supply	220 (+10%; -15 %) V, 50 Hz
Power consumption (without PC and radio station), at most:	
· central point equipment	20 W
· CP equipment	40 W
Range, up to	25 km
Operating Conditions	
Environment temperature	-40 °C to +40 °C
Relative humidity (at temperature under +25 °C), at most	93 %
Reliability	
MTBF, at least	30 000 hours
Life cycle	15 years